

# SINGLE RAIL BARRIER + GROUND BARRIER

## FLEXIBLE PLOYMER

### • Innovative three-layered material

- ① Core strength from within.
- ② Central zone for absorbing impact.
- ③ UV-resistant outer color layer.

Molecular reorientation in the manufacturing process results in a distinctive built-in memory, allowing the barrier to fully recover after impacts.

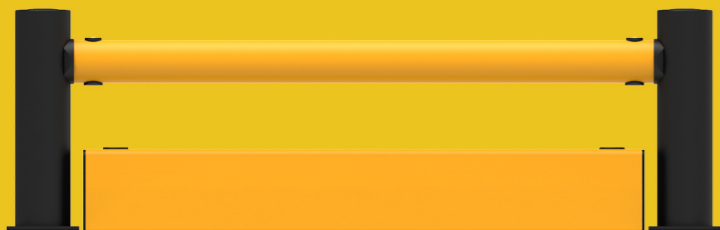
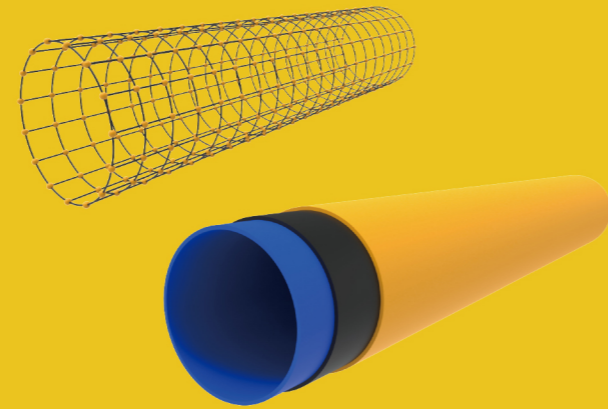

Model	SR100 + GSR190
Height	500mm
Post	φ130mm
Rail	φ100mm
Ground Barrier Size	190mm * 130mm
Length	500~2000mm
BasePlate	170 x 170x 10mm
Fixing (SR100)	8.8 Grade M10 Expansion Bolt
Fixing (GSR190)	8.8 Grade M16 Expansion Bolt 8.8 Grade M20 Chemical Bolt
Impact Energy (SR100)	3850Joule 3 tons Forklift hit at 5.7km/h
Impact Energy (GSR100)	5800 Joule 3 tons Forklift hit at 7km/h
Temperature Range	-5~50°C

### • Advantages

- 1. Crash-Tested
- 2. Quick Disassembly
- 3. Flexible Assembly
- 4. Convenient Maintenance
- 5. Chemical and UV resistance
- 6. Corrosion resistance
- 7. No maintenance
- 8. Safe and non-toxic
- 9. Strong chemical resistance
- 10. No painting required
- 11. Recoverability and Memorability
- 12. Modular combination
- 13. TUV certified
- 14. A tailored solution for every scenario
- 15. Choice of options and heights
- 16. Deflection at Max Energy : 350mm

### • Applications and typical environments

Aotons Single Rail + Ground Barriers protect industrial sites, safeguarding vulnerable areas like storage racks, machinery, electric boxes, conveyors, walls, corners, and building facades. Made durable with high-visibility yellow, they alert drivers for safe operation and resist shallow-angle impacts/fork penetration.

Logistics, supply chain and material handling industries	
Transport and logistics centers	Warehouses and storage facilities
Carpark buildings	(Petro-)chemical plants
Distribution centers	and more

### • Fixations

SR100 :  
M10 Expansion Bolts

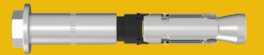

GSR190 :  
M16 Expansion Bolt or  
M20 Chemical Bolt

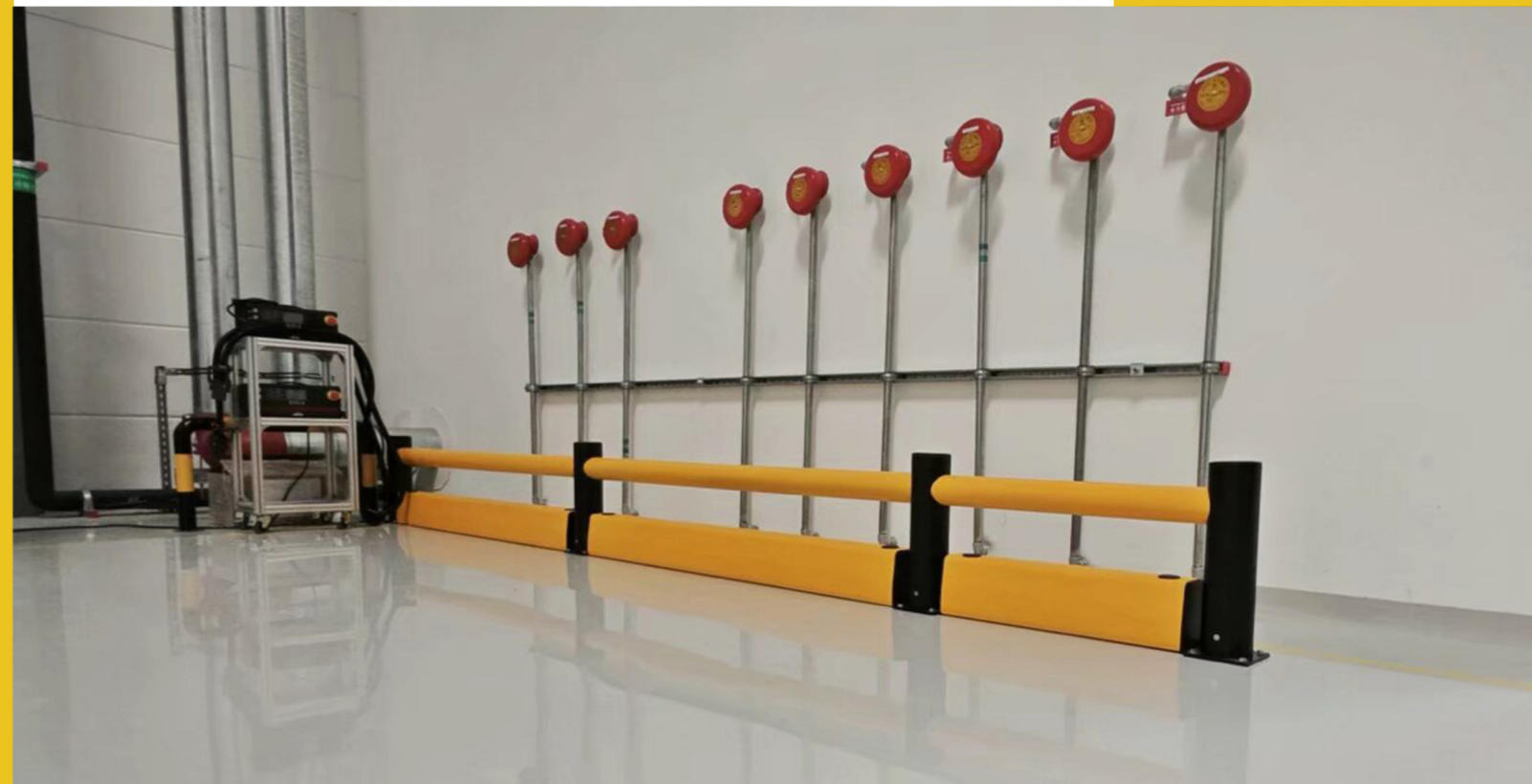

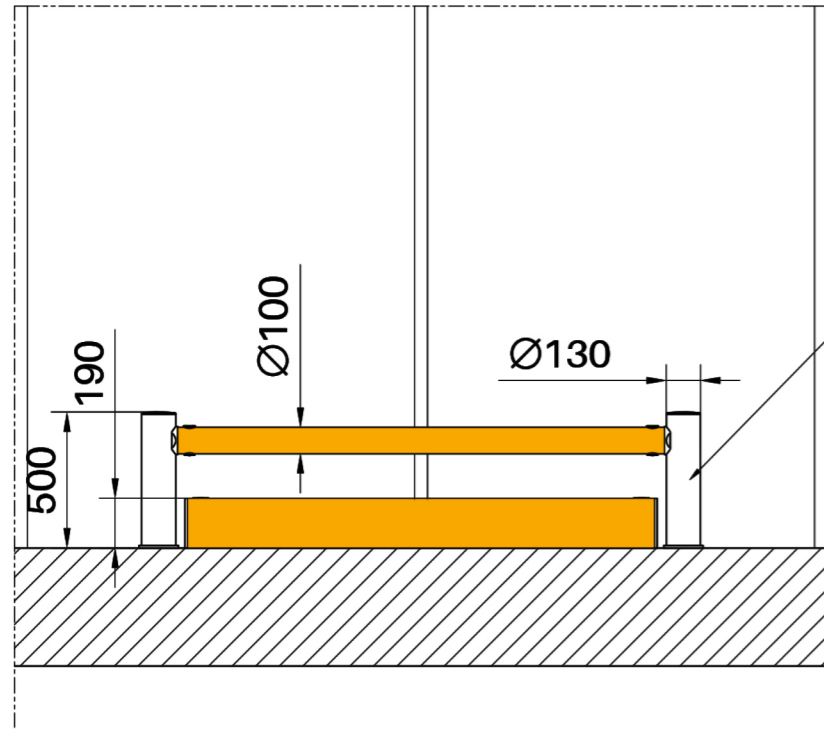

Impact Zone  
0 - 0.45 m height

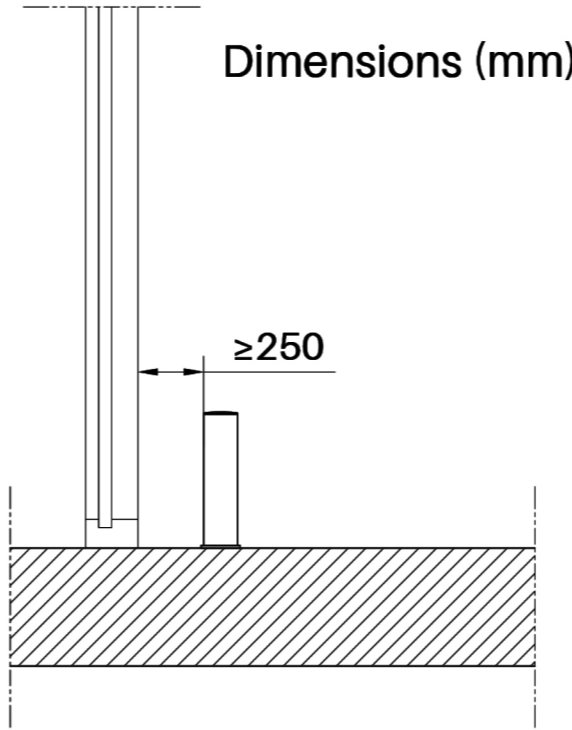

Dimensions (mm)

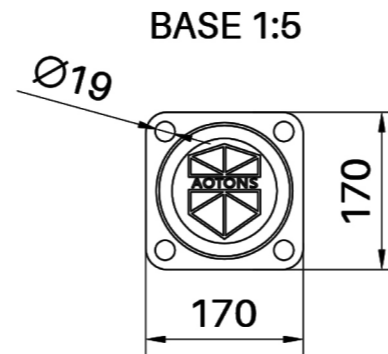
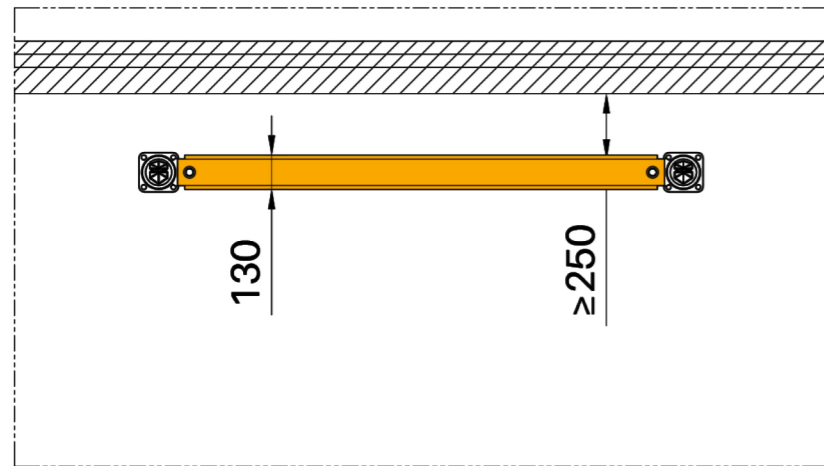

Single Rail Barrier :  
 Rated Impact Energy : 3850 Joule  
 Rated working angle : 45°  
 Post : RAL 9005 , Jet black  
 Rail : RAL 1003 , Signal yellow  
 Bolt : 8.8 grade M10 Expansion Bolt

Single Rail Barrier :  
 Rated Impact Energy : 5800 Joule  
 Rated working angle : 90°  
 Rail : RAL 1003 , Signal yellow  
 Bolt : 8.8 grade M20 Chemical Bolt  
 8.8 grade M16 Expansion Bolt

## SR100 + GSR190

