



THE MOST STRONGEST IMPACT ENERGY COLUMN PROTECTOR

FLEXIBLE PLOYMER

• Innovative three-layered material

- ① Core strength from within.
- ② Central zone for absorbing impact.
- ③ UV-resistant outer color layer.

Molecular reorientation in the manufacturing process results in a distinctive built-in memory, allowing the barrier to fully recover after impacts.

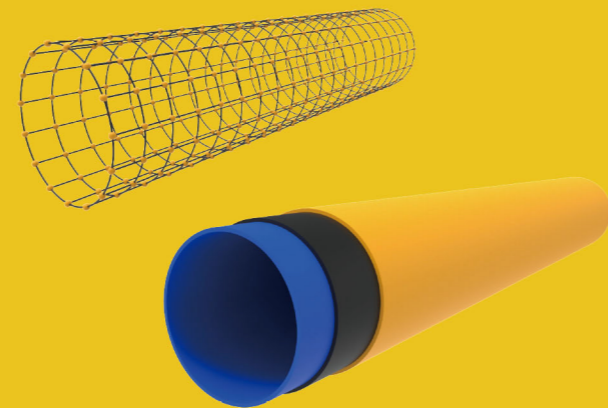

Model	CTR100
Height	1150mm
Post	φ130mm
Rail	φ130mm x 3
Length	600-2000mm
BasePlate	170 x 170 x 10mm
Fixing	8.8 Grade M10 Expansion Bolt
Impact Energy	8760Joule
3tons Forklift hit at	8.4km/h
Temperature Range	-5~50°C

• Advantages

- | | |
|------------------------------|---|
| 1.Coupling Structure | 9.Strong chemical resistance |
| 2.Quick Disassembly | 10.No painting required |
| 3.Flexible Assembly | 11.Recoverability and Memorability |
| 4.Convenient Maintenance | 12.Modular combination |
| 5.Chemical and UV resistance | 13.TUV certified |
| 6.Corrosion resistance | 14.A tailored solution for every scenario |
| 7.No maintenance | 15.Choice of options and heights |
| 8.Safe and non-toxic | 16.Deflection at Max Energy : 320mm |

• Applications and typical environments

Aotons Column protector made from high-quality polymer materials, it combines with flexibility, providing excellent protect for columns, building supports and any size and shape . Flexible column protector provides 360° protection for columns , if without protector columns are damaged or hit by forklift , can lead to serious structural or infrasturecture damage .

Logistics,supply chain and material handling industries	
Transport and logistics centers	Warehouses and storage facilities
Car parkbuildings	(Petro-)chemical plants
Distribution centers	and more

• Fixations

M10 Expansion Bolt

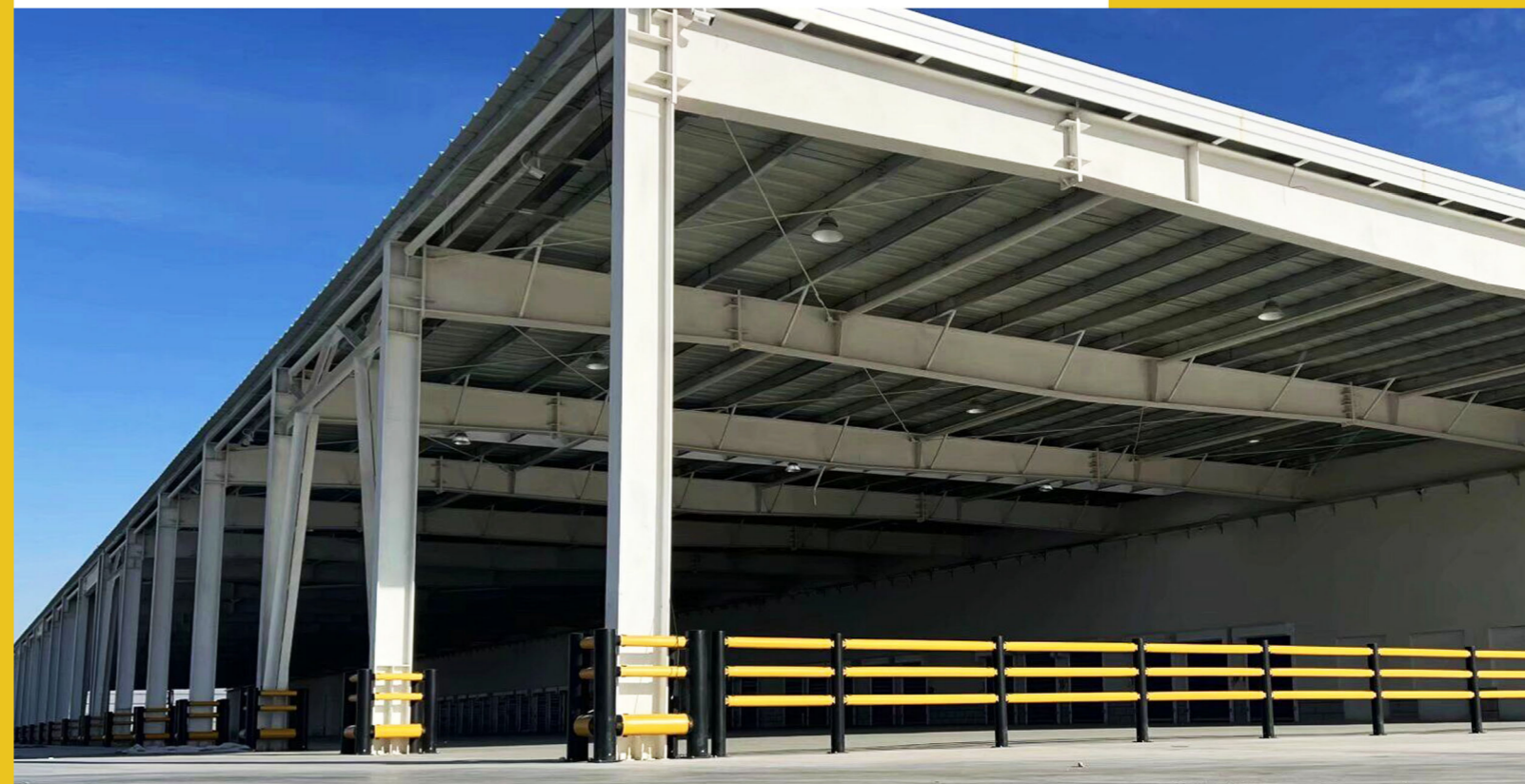

Dimensions (mm)

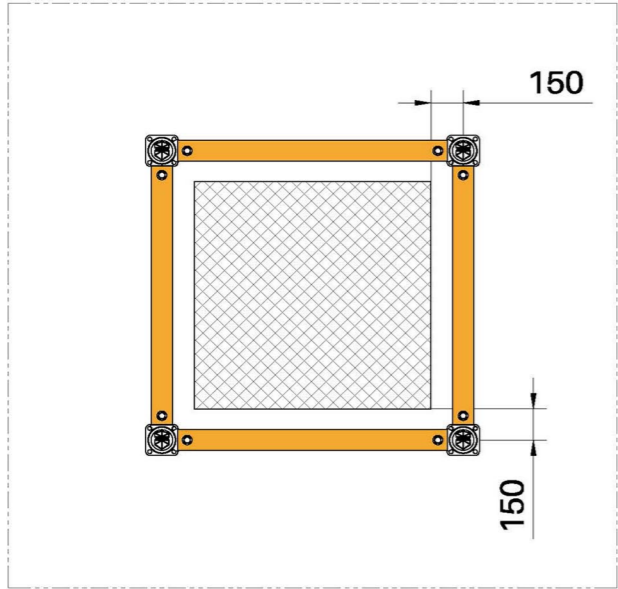
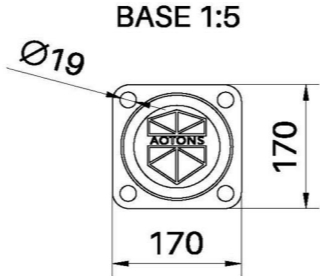
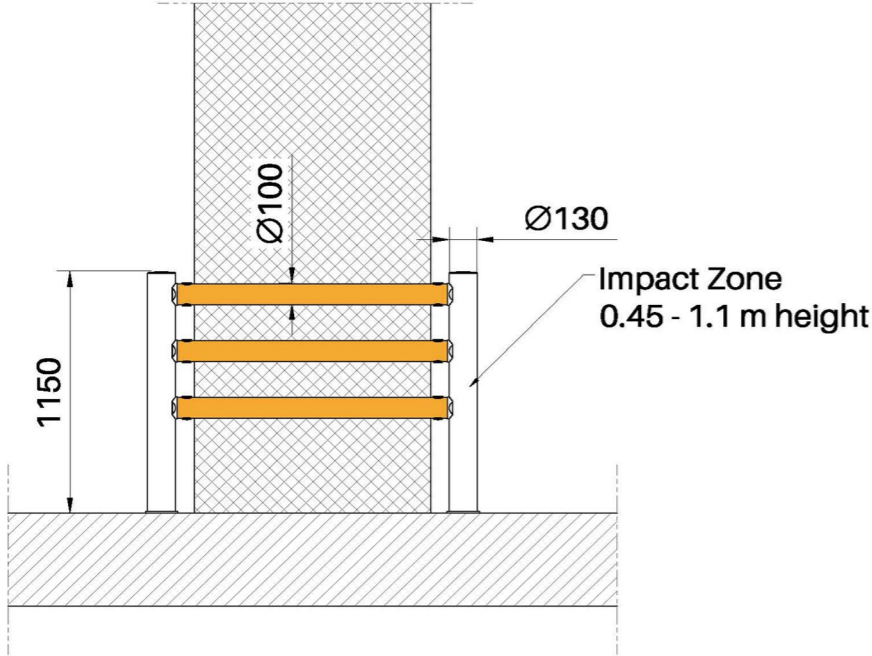

Rated Impact Energy : 8760 Joule
 Rated working angle : 45°
 Post : RAL 9005, Jet black
 Rail : RAL 1003, Signal yellow
 Bolt : 8.8 grade M10 Expansion Bolt

CTR 100

